

A SIMPLE 2-TRANSISTOR TOUCH OR LICK DETECTOR CIRCUIT

BURTON SLOTNICK

UNIVERSITY OF SOUTH FLORIDA

An easily constructed and inexpensive battery operated circuit is described for use as a lickometer or contact detector in behavioral studies with rodents.

Key words: touch circuit, lickometer, contact detector

Contact or touch detectors in which a subject acts as a switch between two metal surfaces have proven more popular and arguably more useful for recording responses than capacitance switches, photocell detectors, and force detectors. Advantages of using such circuits as lick detectors have been addressed by Weijnen (1989, 1998). A variety of such detectors are commercially available but are relatively expensive. Components for touch detectors circuits are inexpensive and, except for some special purpose designs (e.g., Overton & Overton, 2007), can be easily constructed in the laboratory. Advances in solid state components and circuit design, since the original report by Hill and Stellar (1951) on the use of “drinkometers” for detecting lick behavior of rats, make possible a variety of designs using only transistors, or operational amplifiers, CMOS comparators, and other integrated circuits. One such design using an LM741 operational amp has been recently reported (Anger & Schachtman, 2007). The criteria for recommending the circuit shown in Figure 1 are (1) it is simple to construct and uses widely available and inexpensive components, (2) the current experienced by the subject is less than 1 μa , (3) it does not require shielded lines, (4) because it is battery operated, it is independent of a dc power supply and AC line current and, hence, does not require an isolation transformer to protect the subject, and (5) its output operates a relay whose contacts can be used to switch whatever voltage (or ground) might be needed by a computer interface input line or other control equipment.

The circuit has been used to detect tongue contacts with a drinking tube with mice and, in our experience, has proven reliable. Shielded lines to the subject have not been used although these may be required in electrically ‘noisy’ laboratories. Tests in which a motor-driven cam operating a microswitch (approximately 30 ms on-time) was used to mimic lick behavior demonstrated that the circuit would follow contacts at at least 30 per s. Operations in which an equal duty on (contact) and off (no contact) cycle was used at 25 operations per s produced a battery drain from a 9-V alkaline battery of less than 3.5 V after more than 8 million operations (‘licks’). As a supply voltage of at least 5.5 V is required for reliable operation of the relay, a single 9-V DC alkaline battery would probably be sufficient for many weeks or months of use for most experimental situations. Much longer service would be obtained with a lithium 9-V DC battery. If preferred, a zener diode could be used to operate the unit at a fixed voltage (e.g., 6.3-V DC) from a 24-V DC power supply (as described by Field & Slotnick, 1987). Doing so would eliminate the need for a battery and would maintain a constant voltage and, hence, a fixed current (of approximately 0.3 μa) across the subject. Of course, even when the supply voltage is fixed, current experienced by the subject will vary with subject resistance. In tests with human subjects using the circuit in Figure 1, current varied from 0.2 μa across dry fingers (as might occur if the circuit were used to monitor activity with a chamber floor having multiple metal plates) and between 0.4 and 0.5 μa across one wet and one dry finger (as might occur if the circuit were used to monitor drinking between a metal floor and a metal drink tube). R1 in Figure 1 could be increased to 15M–20M ohms to further reduce current experienced by the subject but this might result

Correspondence may be addressed to the author at Department of Psychology, University of South Florida, 4202 E. Fowler Ave., Tampa, FL 33620 (e-mail: slotnic@american.edu).

doi: 10.1901/jeab.2009.91-253

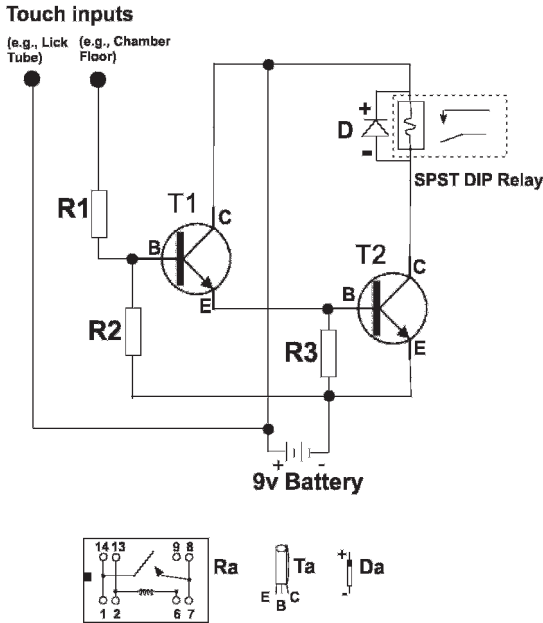

Fig. 1. Battery operated touch detector circuit. R1 and R2, 10 megohm resistors. R3, 47K ohm resistor. T1 and T2, 2N2222 transistors. E, B, C, indicate the emitter, base, and common lines of the transistors. D, diode. Ra, pin numbers of a 14 pin DIP socket and the corresponding positions of normally open and common relay contacts, and the relay coil (as viewed from above the relay). Ta shows the position of the transistor emitter, base, and common lines viewed from its flat surface. Da, the positive and negative connections of the diode.

in a decrease in sensitivity and reliability except, perhaps, when the unit is used as a lick detector. Some precautions in using electrical lick detectors for studying the microstructure of licking and with concurrent electrophysiological recordings are described by Weijnen (1989, 1997, 1998). As discussed by Weijnen, rats can probably detect currents of less than $0.1 \mu\text{A}$ but a current below $0.5 \mu\text{A}$ appears to have little or no influence on various measures of licking.

The EDR relay (Figure 1) fits into a 14-pin DIP socket and its electrical life is in excess of 10 million operations (see <http://yorkbrown.net/balloon/docs/ReedRelay.pdf>). Note that some EDR relays contain a diode across the coil. If one of these is used, the external diode in Figure 1 should not be used and you must insure the polarity of your connections to the coil are correct.

The circuit shown in Figure 1 has been used to record responding in the olfactometer described by Slotnick and Restrepo (2005). A

more formal test of performance was conducted using a modification to insure individual licks would be recorded. Three adult female CF-1 strain mice maintained on a 1-ml/day water deprivation schedule were allowed to drink from a stainless steel 14G Popper feeding tube whose ball end was slightly recessed into a plastic tube made from a 10-cc syringe barrel. The circuit output was connected to a digital interface and the control program counted each pair of onset and offset signals as a lick. Licks by mice were reinforced with $3 \mu\text{l}$ of water on a variable interval 5-s schedule and the number of nonreinforced licks in 1-s bins were recorded. Bin counts varied from 0 to 11 (mean 6.4). Excluding bin counts less than 2 (within which the mouse obviously paused in licking), the mean lick rate was 7.9 licks per s, a value that is well within those reported for lick rate in various strains of mice (Boughter, Baird, Bryant, St. John, & Heck, 2007).

Although the circuit in Figure 1 should prove generally useful for monitoring contacts of rodents between two conducting surfaces, there are several potential disadvantages of this circuit. It probably would not be useful for studying current detection threshold as this would require reliable operation with currents in the submicroampere range. Two components, the battery and the relay, have finite life expectancies. The relay is rated at many millions of operations and, if seated in a DIP socket, can be easily replaced. While an optocoupler could be used in place of the relay, this would further complicate the circuit and provide a more limited choice of outputs. Battery drain may be a greater concern because, as voltage decreases, the current across the subject and sensitivity of the unit will decrease and, at a sufficiently low voltage, the unit will fail. Although the potential decrease in sensitivity can be resolved by incorporating a zener diode across the battery terminals, in practice the battery is long-lasting and its voltage remains well above that needed for reliable operation for many millions of contacts. However, if sustained contact of the subject between two surfaces is expected, the unit should probably be operated from a standard laboratory power supply.

Components can be purchased from most electronic supply stores. For convenience, Jameco and Radio Shack company part num-

bers are supplied. Before soldering connections it may be useful to build the circuit on a modular IC breadboard socket (e.g. Radio Shack PN 276-003) to insure all components are functioning as expected.

Relay: EDR SPST DIP relay, 500 ohm coil (Jameco PN 106463). Less than \$3 ea.

Relay socket: 14 pin DIP (Jameco PN 526192). Less than \$0.10 ea.

R1 and R2: 10M $\frac{1}{2}$ watt resistors (Jameco PN 662477). Approximately \$4/100.

R3: 47K $\frac{1}{2}$ watt resistor (Jameco PN 661917). Approximately \$4/100.

T1 and T2: 2N2222A transistors (Jameco PN 178511). Less than \$0.25 each.

PC board: The circuit can easily be built on a 1 $\frac{3}{4}$ inch square copper clad PC board (Radio Shack PN 276-148).

REFERENCES

- Anger, D., & Schachtman, T. R. (2007). A sensitive, reliable inexpensive touch detector. *Journal of the Experimental Analysis of Behavior*, 87, 151–153.
- Boughter, J. D., Baird, J. P., Bryant, J., St John, S. J., & Heck, D. (2007). C57BL/6J and DBA/2J mice vary in lick rate and ingestive microstructure. *Genes, Brain and Behavior*, 6, 619–627.
- Field, B., & Slotnick, B. (1987). A multi-purpose photocell and touch circuit amplifier. *Physiology and Behavior*, 40, 127–129.
- Hill, J. H., & Stellar, E. (1951). An electronic drinkometer. *Science*, 114, 43–44.
- Overton, R. L., & Overton, D. A. (2007). A high-sensitivity drinkometer circuit with 60-Hz filtering. *Behavior Research Methods*, 39, 118–122.
- Slotnick, B., & Restrepo, D. (2005). Olfactometry with mice. *Current Protocols in Neuroscience*, Unit 8.20. Wiley InterScience.
- Weijnen, J. A. (1989). Lick sensors as tools in behavioral and neuroscience research. *Physiology and Behavior*, 46, 923–928.
- Weijnen, J. A. (1998). Licking behavior in the rat: measurement and situational control of licking frequency. *Neuroscience and Biobehavioral Reviews*, 22, 751–760.
- Weijnen, J. A. W. M. (1997). The recording of licking behavior. In J. A. W. M. Weijnen, & J. Mendelson (Eds.), *Drinking behavior: Oral stimulation, reinforcement and preference*, New York: Plenum Press.

Received: August 31, 2008

Final acceptance: November 24, 2008